

# APPENDIX F

## Figure 1

### SUPPLY CHAIN COST DIAGRAM

Retail Automotive Fuels  
Zone 1 - Avalon Peninsula  
Product from Avalon Terminals

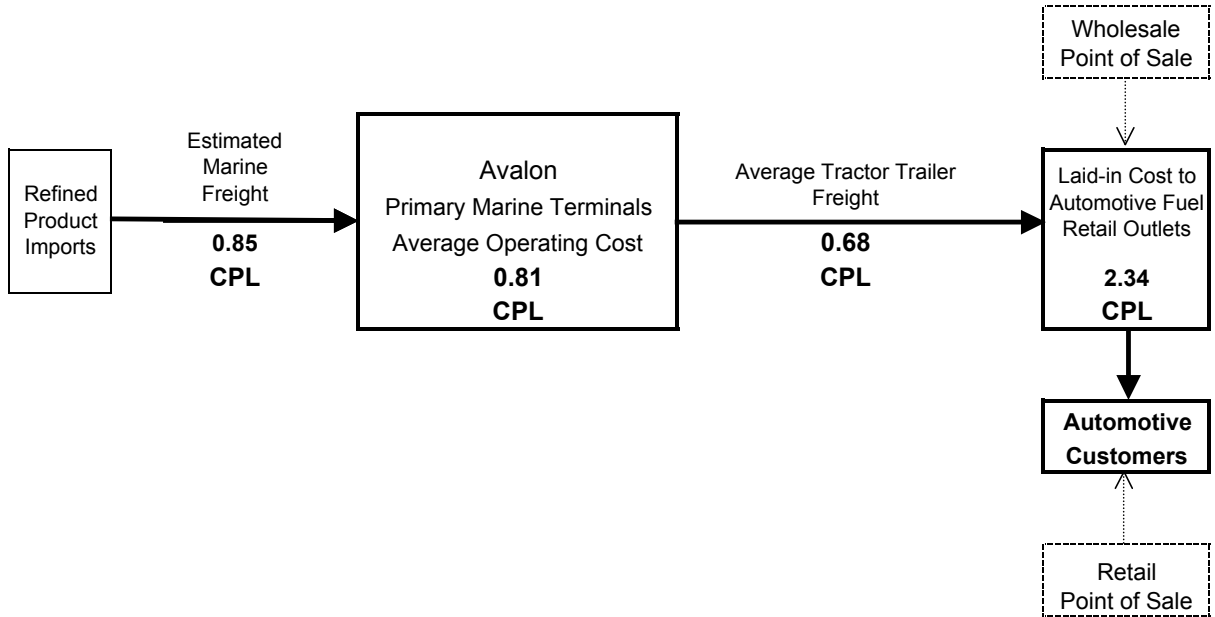

## Figure 1a

### SUPPLY CHAIN COST DIAGRAM

Retail Automotive Fuels  
Zone 1a - Bell Island  
Product from Avalon Terminals

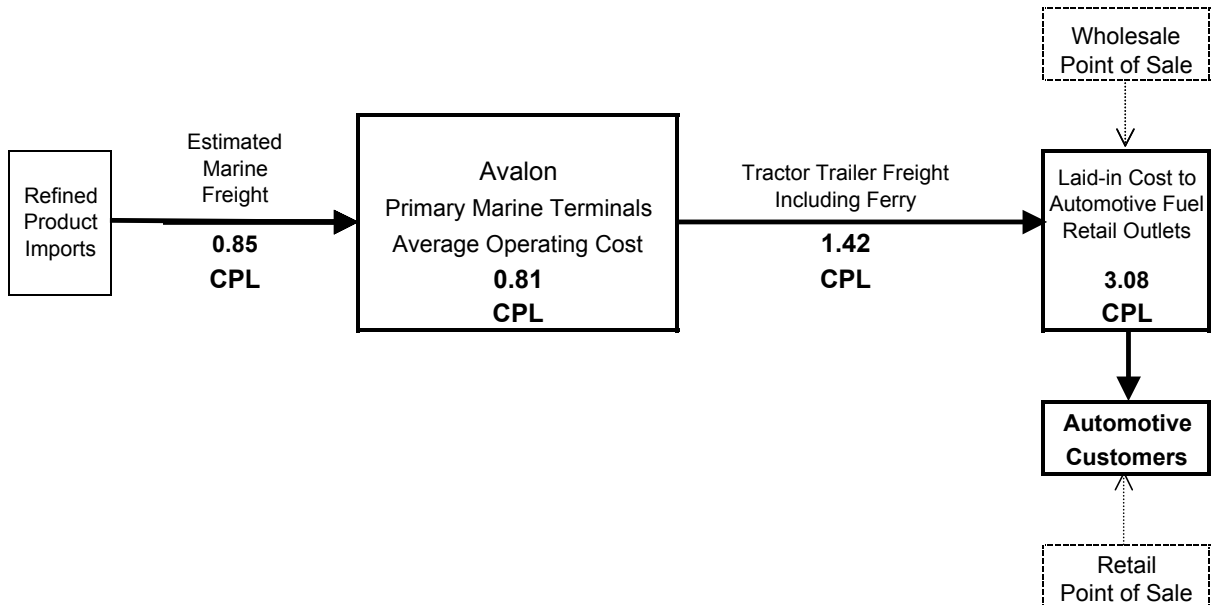

# APPENDIX F

## Figure 2

### SUPPLY CHAIN COST DIAGRAM

Retail Automotive Fuels  
Zone 2 - Burin-Bonavista Peninsulas  
Product from Avalon Terminals

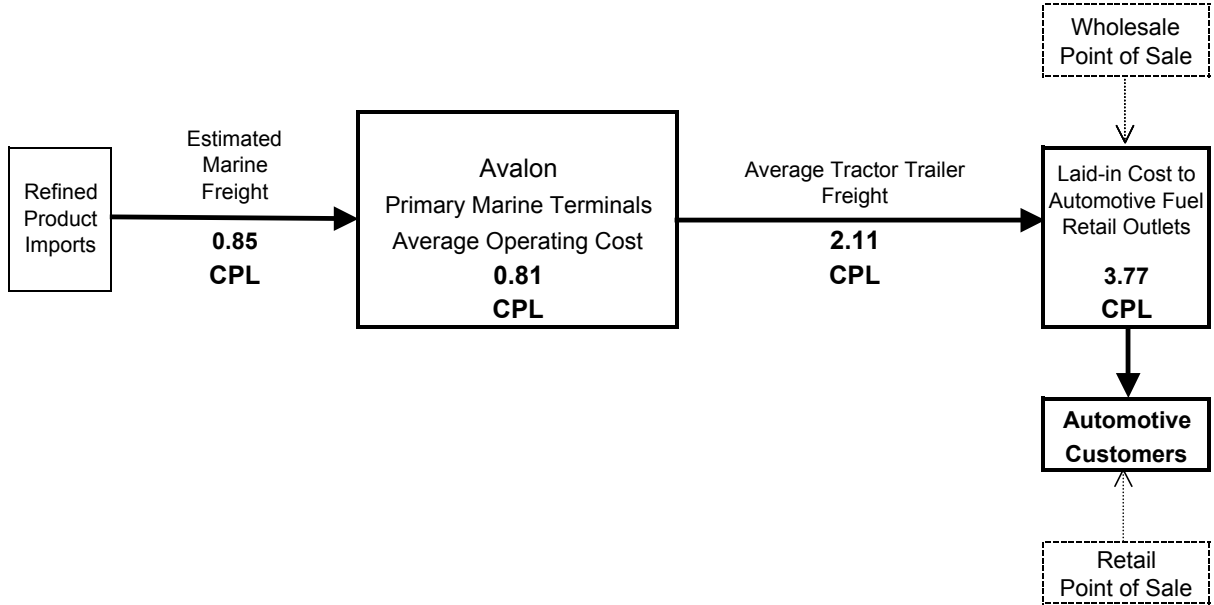

# APPENDIX F

**Figure 3**  
**SUPPLY CHAIN COST DIAGRAM**  
 Retail Automotive Fuels  
**Zone 3 - Central Newfoundland**  
 Product from Avalon Terminals

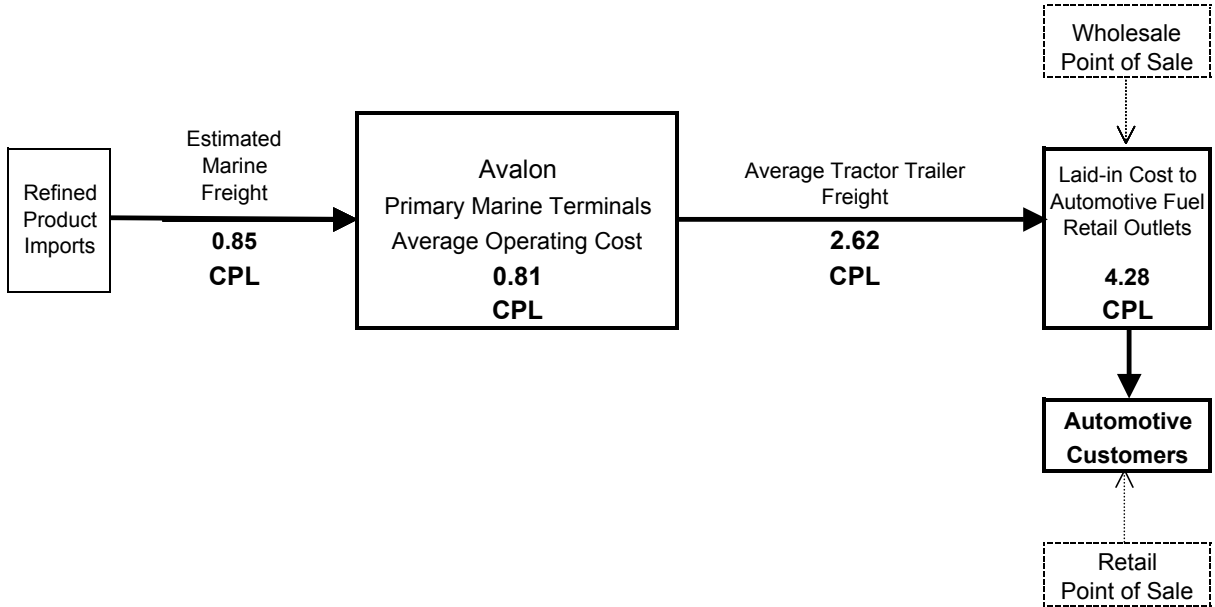

**Figure 3a**  
**SUPPLY CHAIN COST DIAGRAM**  
 Retail Automotive Fuels  
**Zone 3a - St. Brendan's (Island)**  
 Product from Avalon Terminals

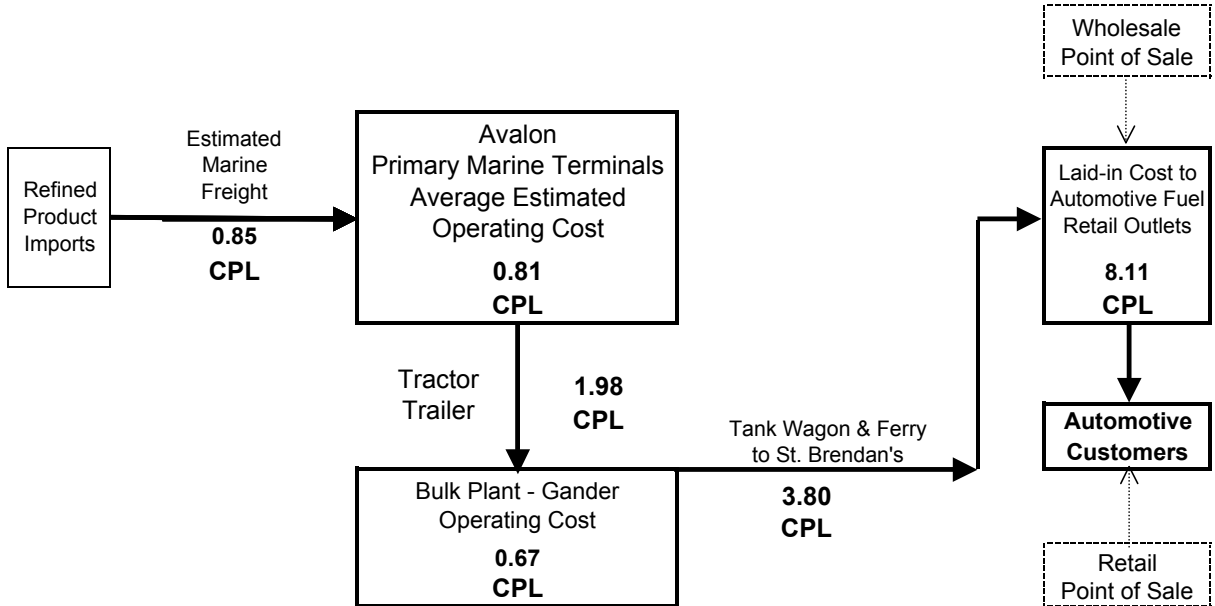

# APPENDIX F

## Figure 3b

### SUPPLY CHAIN COST DIAGRAM

Retail Automotive Fuels

Zone 3b - Fogo Island

Product from Avalon Terminals

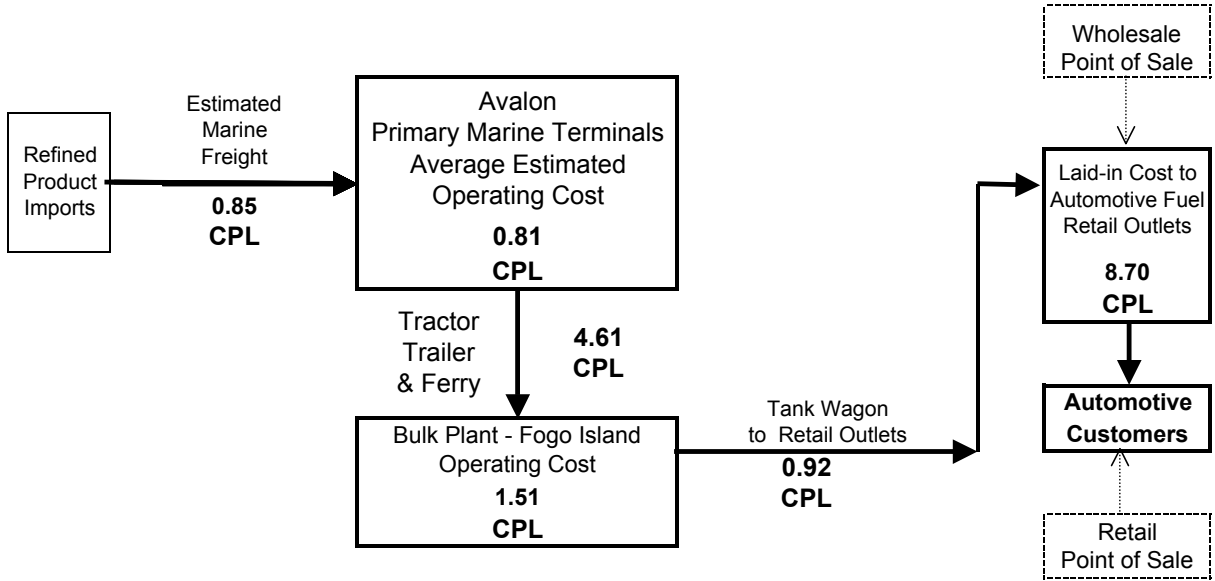

## Figure 3c

### SUPPLY CHAIN COST DIAGRAM

Retail Automotive Fuels

Zone 3c - Change Islands

Product from Avalon Terminals via Fogo Bulk Plant

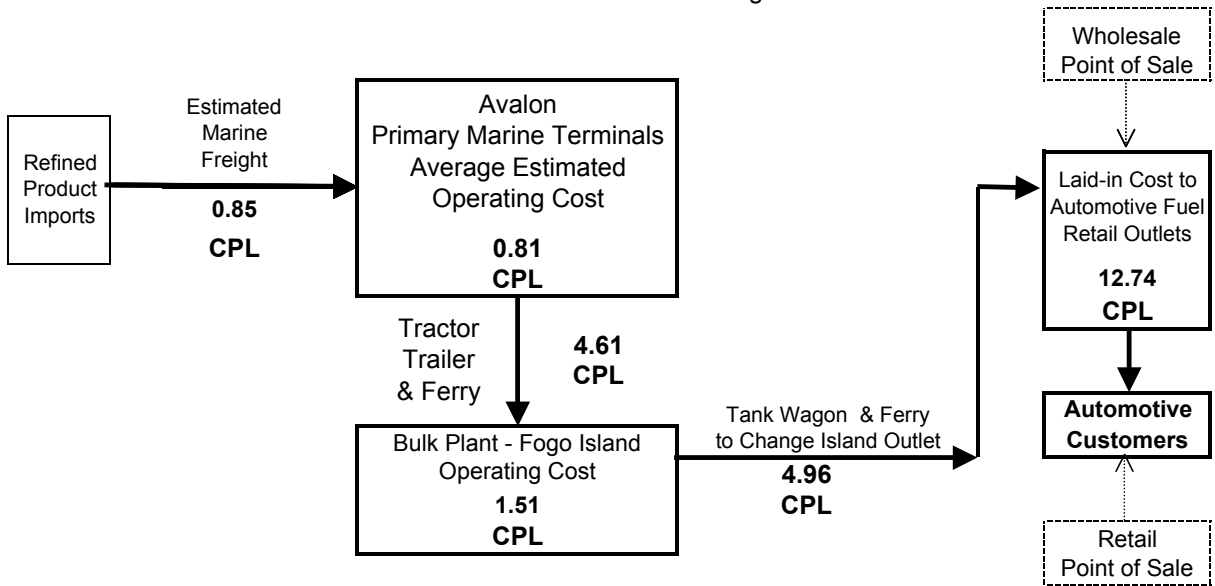

## APPENDIX F

**Figure 4**  
**SUPPLY CHAIN COST DIAGRAM**  
 Retail Automotive Fuels  
**Zone 4 - Connaigre Peninsula**  
 Product from Avalon Terminals

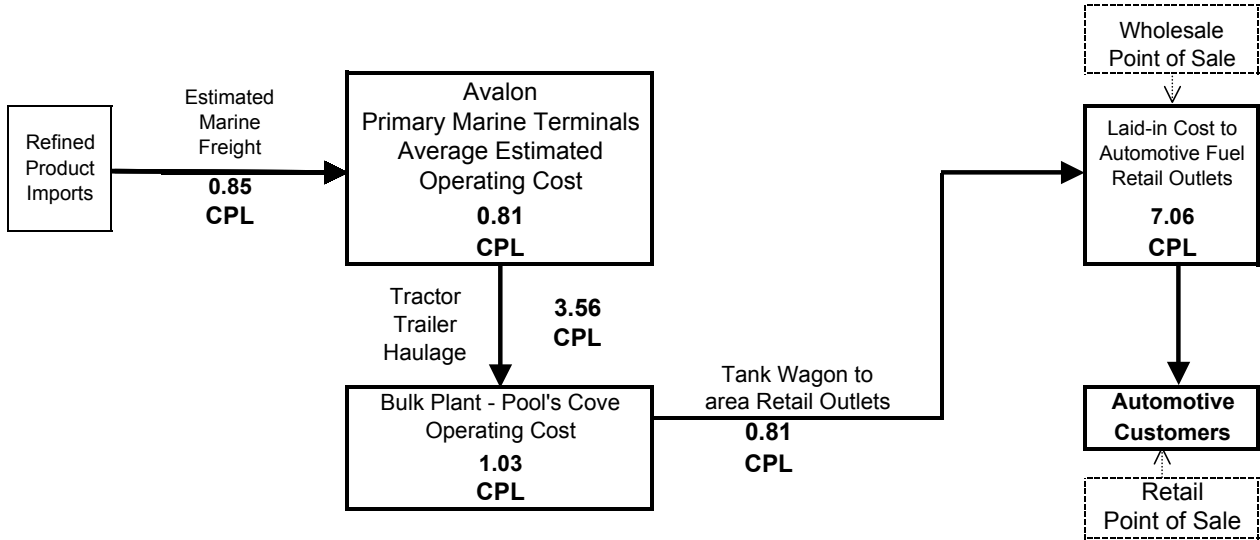

**Figure 4a**  
**SUPPLY CHAIN COST DIAGRAM**  
 Retail Automotive Fuels  
**Zone 4a - Gaultois-McCallum / Rencontre East**  
 (Drums from Hermitage and Pool's Cove - Connaigre Peninsula)

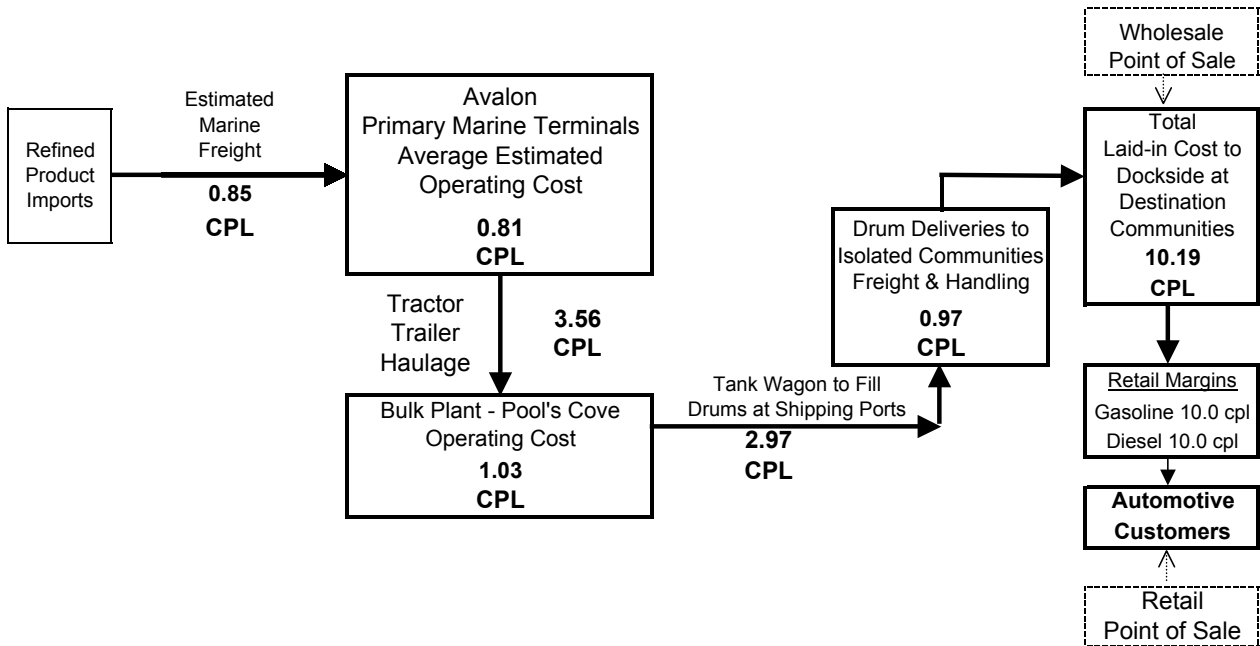

# APPENDIX F

## Figure 5

### SUPPLY CHAIN COST DIAGRAM

Retail Automotive Fuels

Zone 5 - Springdale and Baie Verte areas via Bulk Plant at Springdale

Product from Corner Brook Terminals

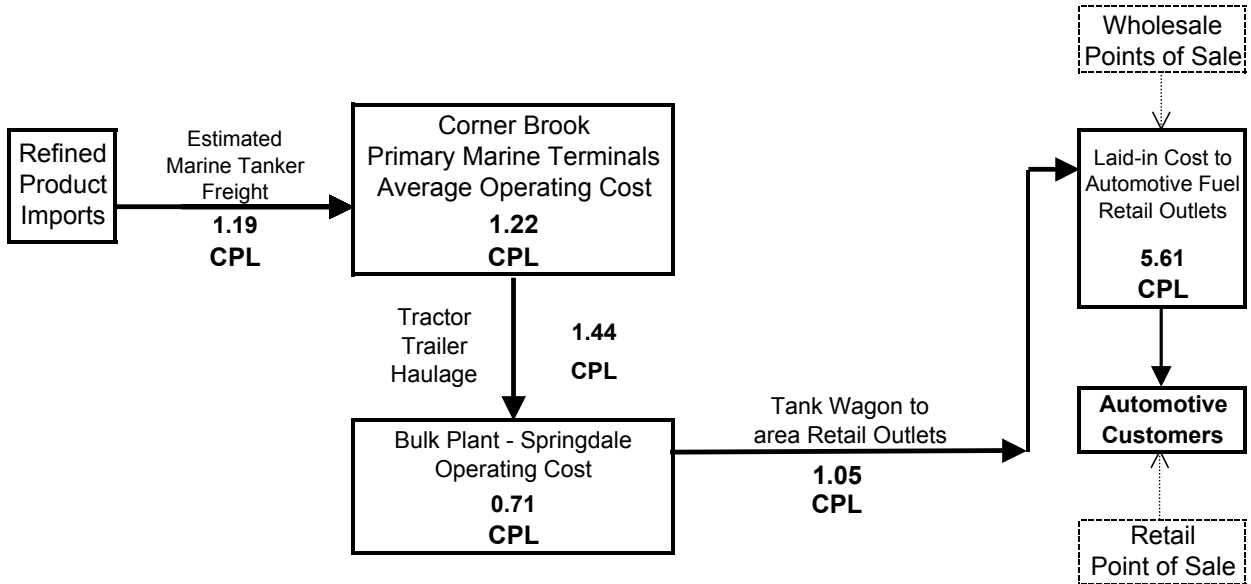

## APPENDIX F

**Figure 5a**

### SUPPLY CHAIN COST DIAGRAM

Retail Automotive Fuels  
**Zone 5a - Long Island via T/W from Springdale Bulk Plant**  
 Product from Corner Brook Terminals

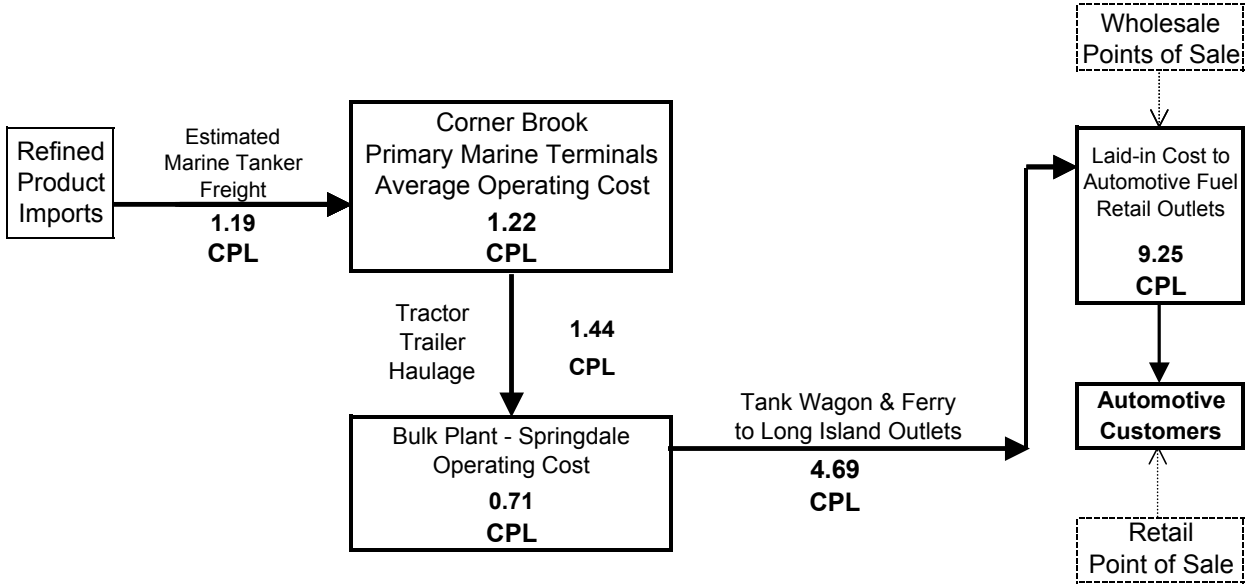

**Figure 5b**

### SUPPLY CHAIN COST DIAGRAM

Retail Automotive Fuels  
**Zone 5b - Little Bay Islands via T/W from Springdale Bulk Plant**  
 Product from Corner Brook Terminals

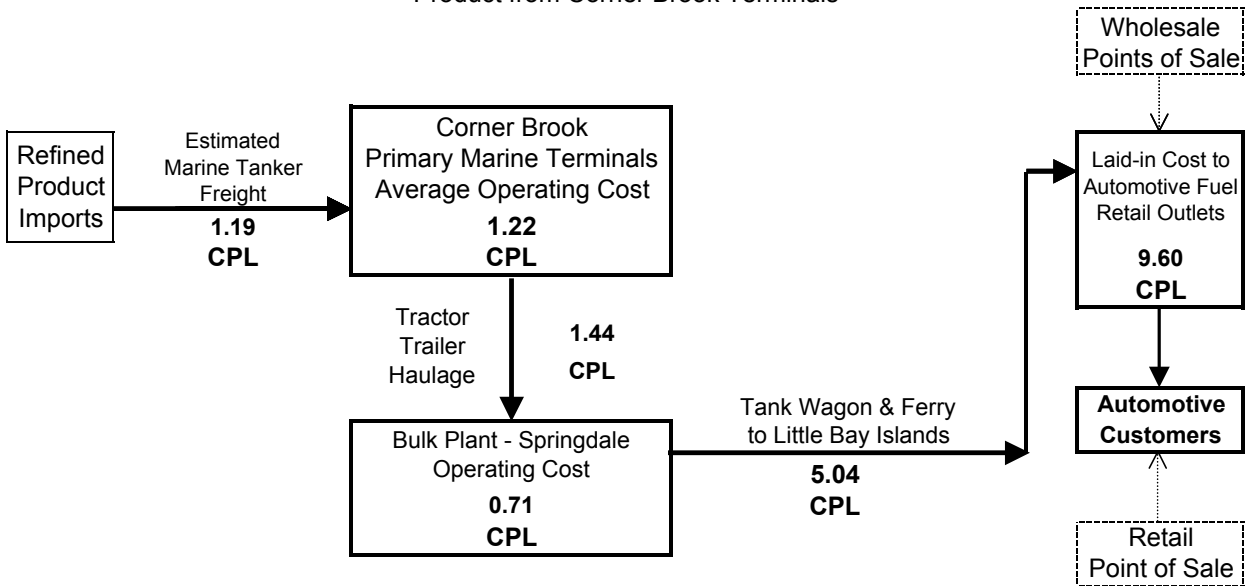

# APPENDIX F

## Figure 6

### SUPPLY CHAIN COST DIAGRAM

Retail Automotive Fuels  
**Zone 6 - Corner Brook and Area**  
Product from Corner Brook Terminals

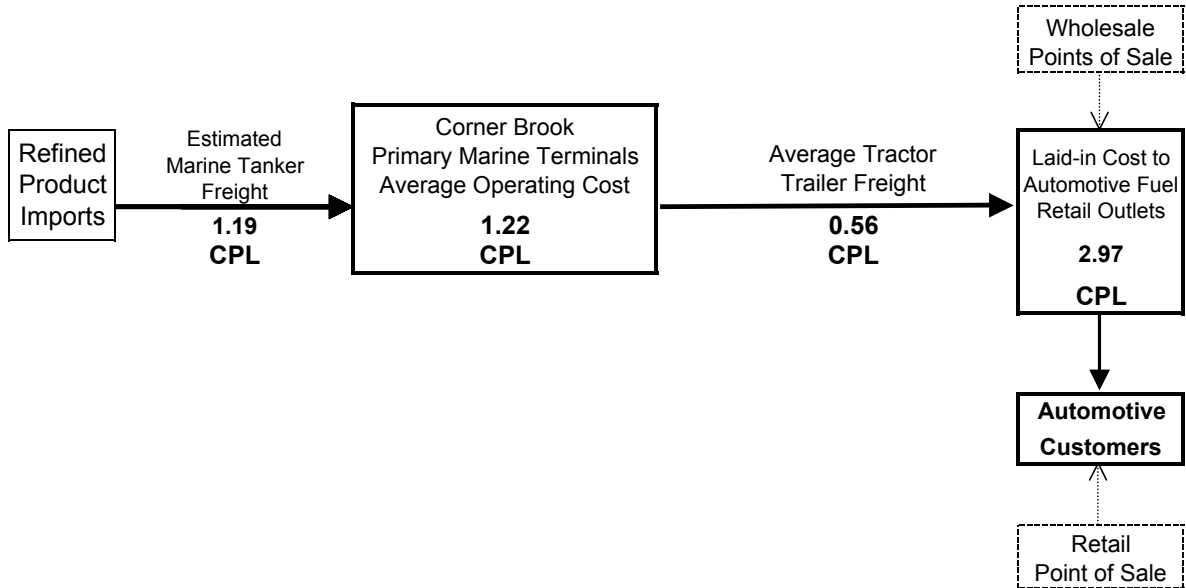

## Figure 7

### SUPPLY CHAIN COST DIAGRAM

Retail Automotive Fuels  
**Zone 7 - Stephenville - Port aux Basques - Burgeo**  
Product from Corner Brook Terminals

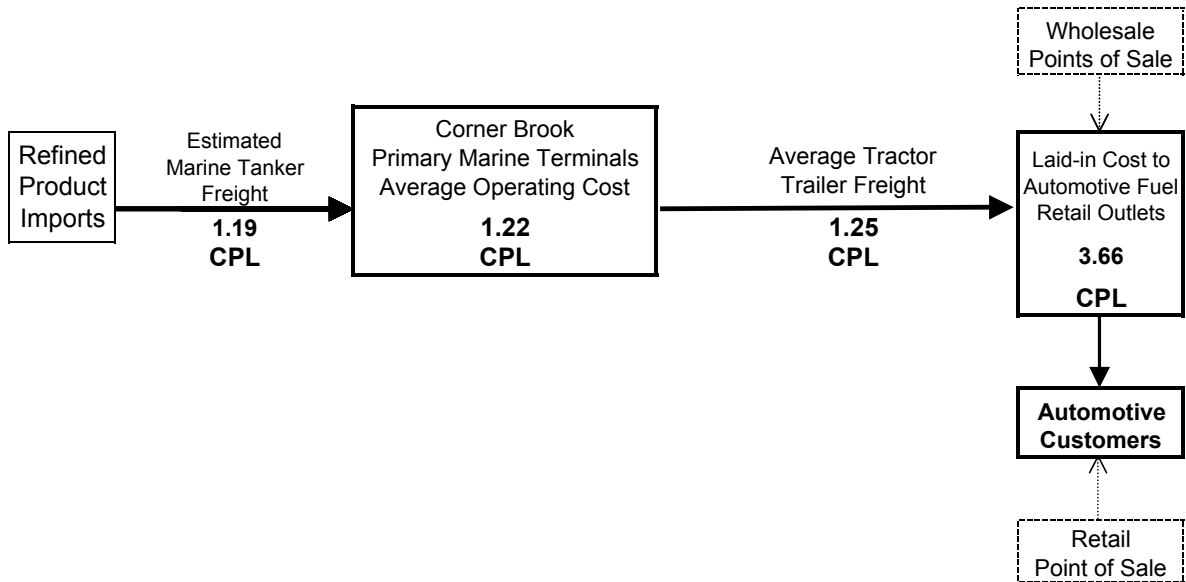



**APPENDIX F**

**Figure 7a**

**SUPPLY CHAIN COST DIAGRAM**

Retail Automotive Fuels

**Zone 7a - Ramea Island**

Product from Corner Brook Terminals

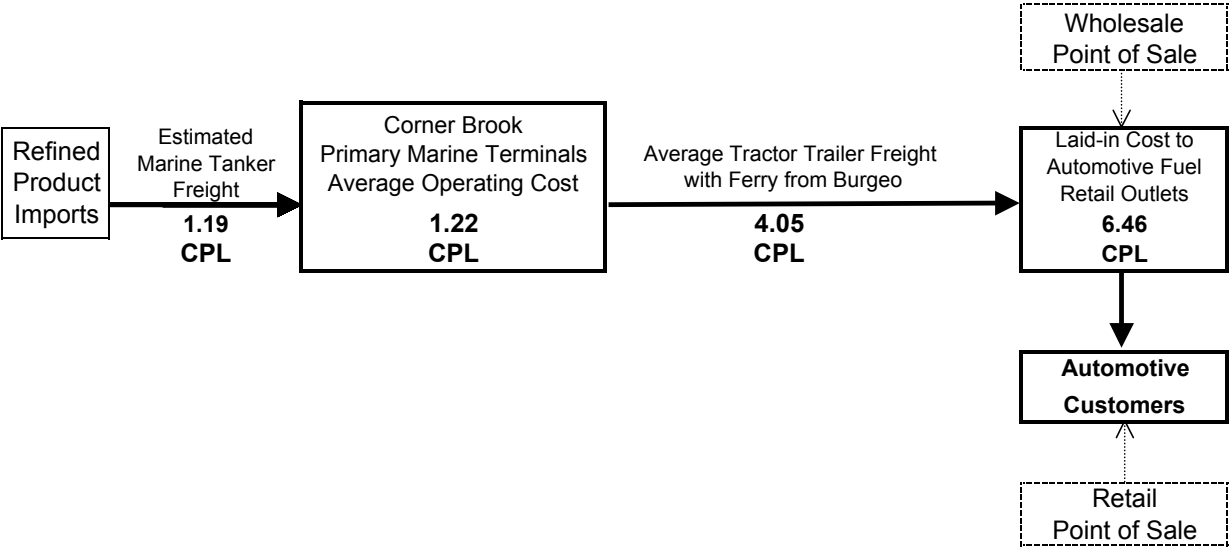

## APPENDIX F

Figure 7b1

### SUPPLY CHAIN COST DIAGRAM (GASOLINE)

Zone 7b - Grey River & Francois / La Poile & Grand Bruit  
(Drums from Burgeo Shipped via Freight Ferry)

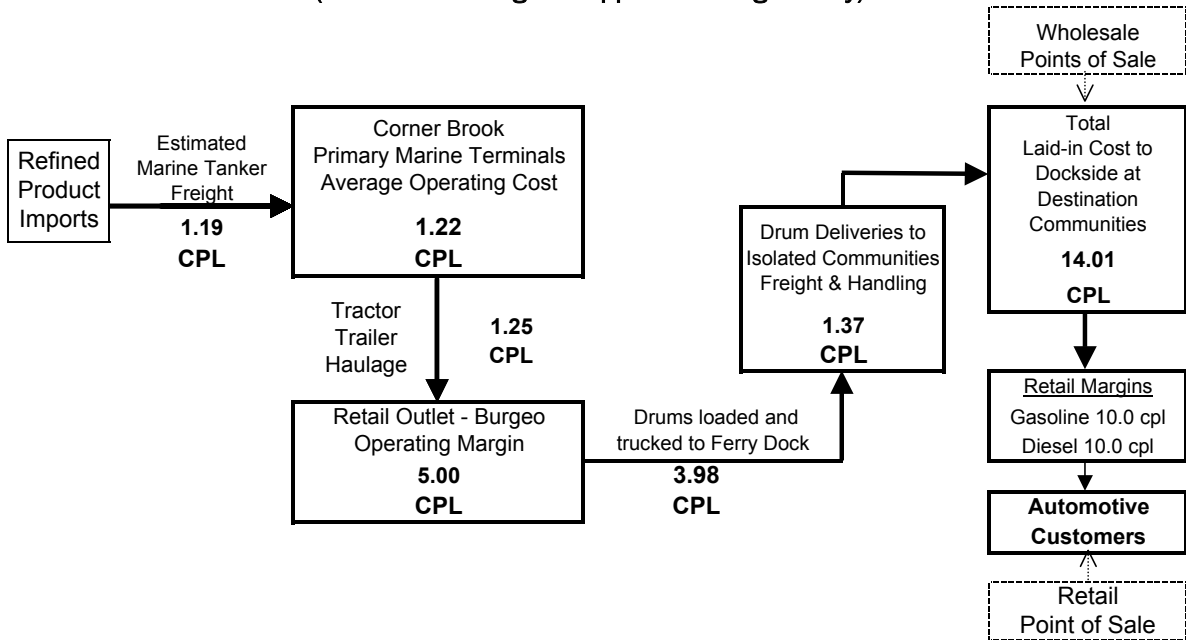
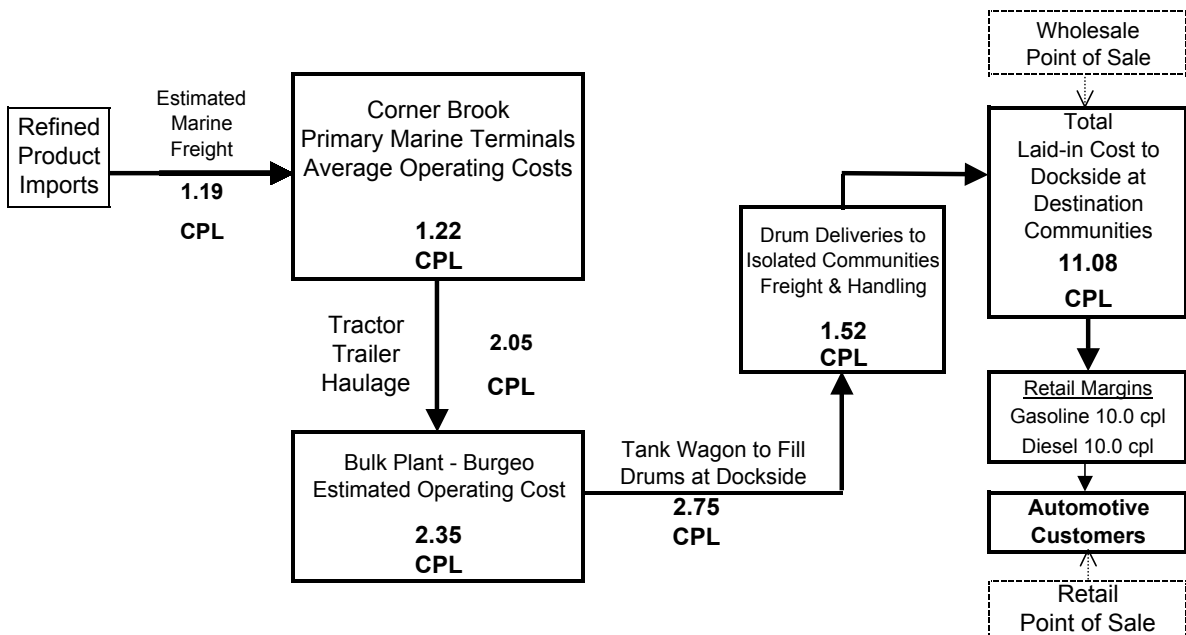

Figure 7b2

### SUPPLY CHAIN COST DIAGRAM (DIESEL FUEL)

Zone 7b - Grey River & Francois / La Poile & Grand Bruit  
(Drums from Burgeo Shipped via Freight Ferry)



# APPENDIX F

## Figure 8

### SUPPLY CHAIN COST DIAGRAM Retail Automotive Fuels Zone 8 - Northern Peninsula South Product from Corner Brook Terminals

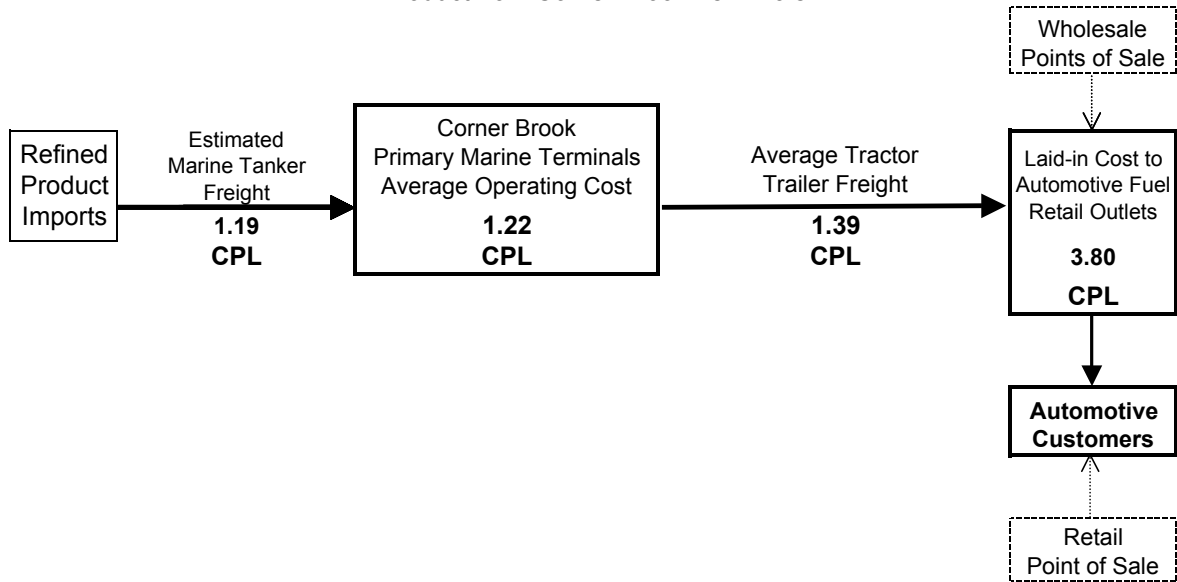

## Figure 9

### SUPPLY CHAIN COST DIAGRAM Retail Automotive Fuels Zone 9 - Northern Peninsula North Product from Corner Brook Terminals

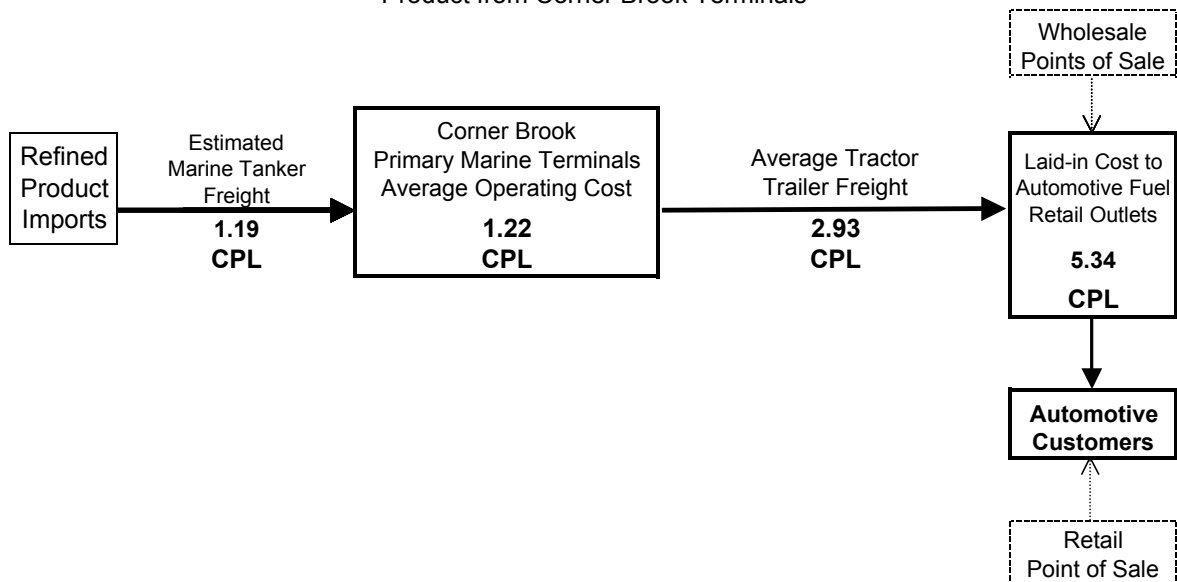

## APPENDIX F

**Figure 10**  
**SUPPLY CHAIN COST DIAGRAM**  
**Retail Automotive Fuels**  
**Zone 10 - Labrador - The Straits**  
 Product from Local Marine Depots

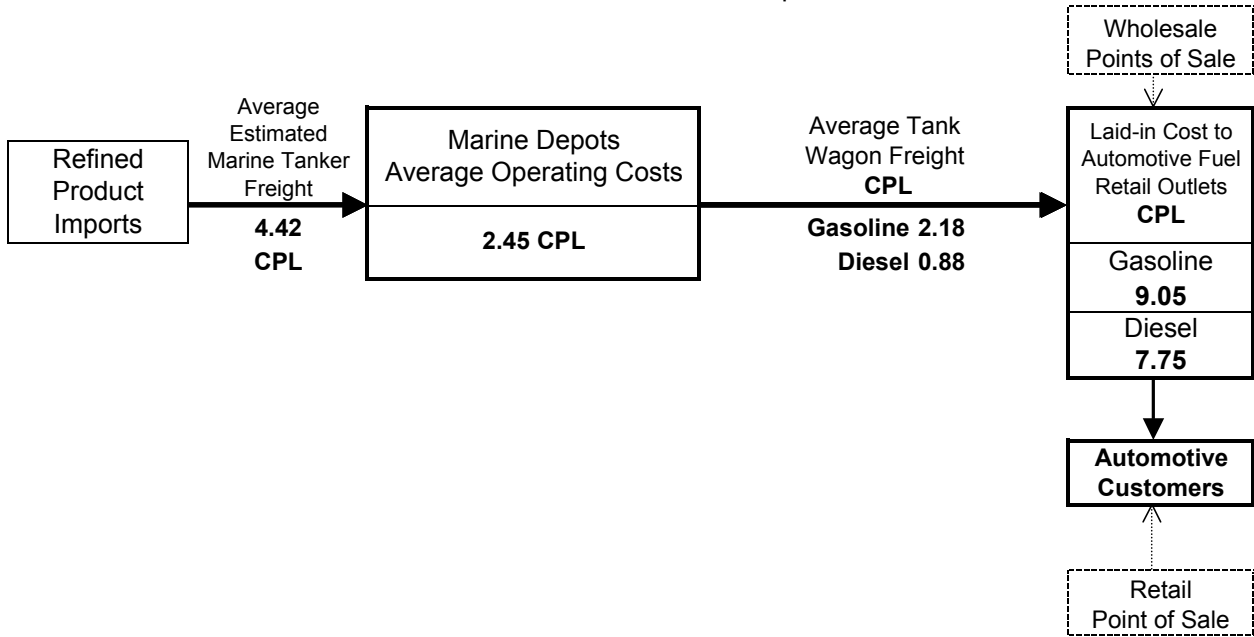

**Figure 11**  
**SUPPLY CHAIN COST DIAGRAM**  
**Retail Automotive Fuels**  
**Zone 11 - Labrador South - Lodge Bay to Cartwright**  
 Product from Local Depots

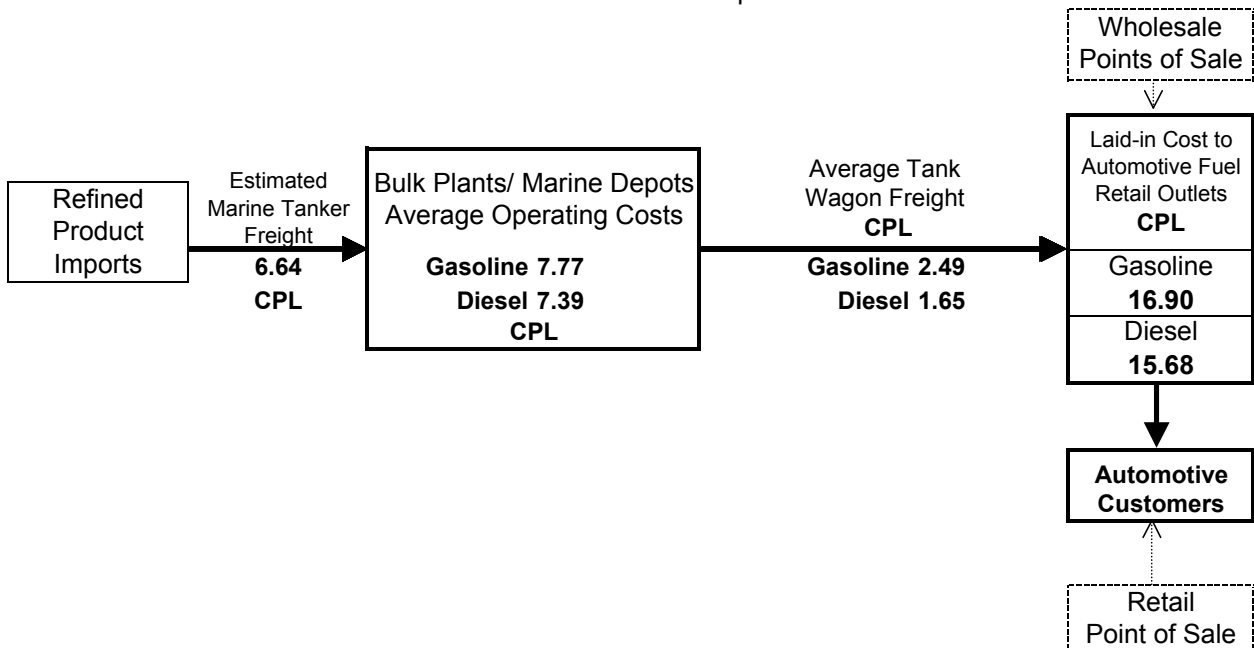

## APPENDIX F

### FIGURE 11a

SUPPLY CHAIN COST DIAGRAM

#### Retail Automotive Fuels Zone 11a - Labrador Coast South - (Isolated Communities) Product from Local Marine Depots

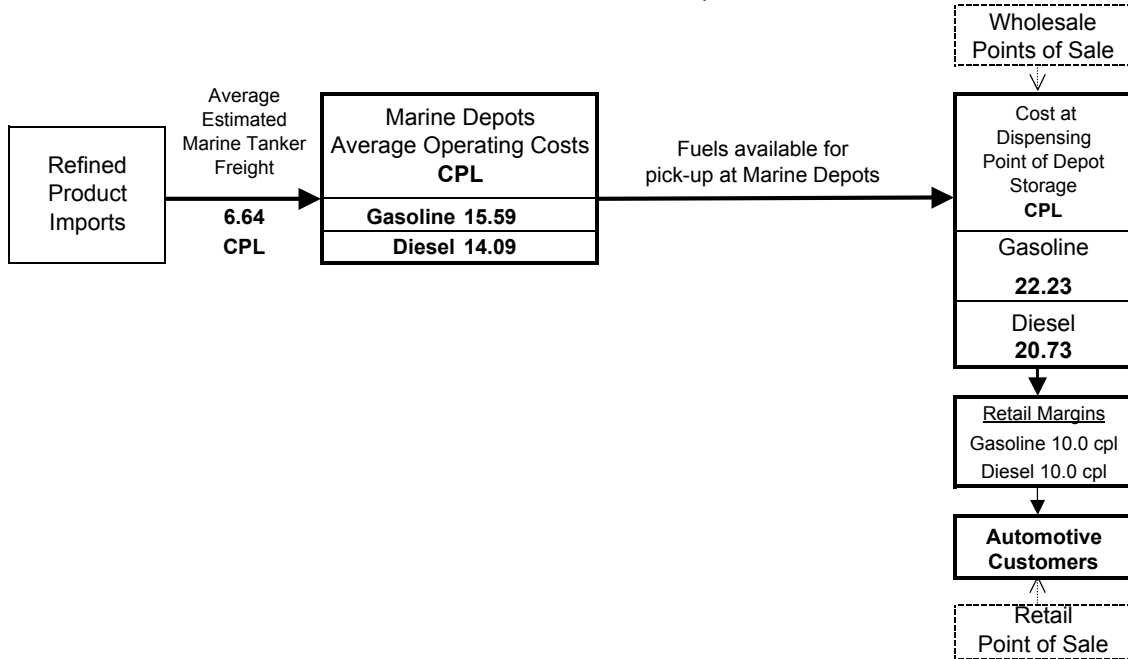

### FIGURE 11b

SUPPLY CHAIN COST DIAGRAM

#### Retail Automotive Fuels Zone 11b - Williams Harbour - Norman Bay - Other Isolated Coastal Communities (Drums from Charlottetown or Post Hope Simpson shipped via Freight Ferry) Product from Local Marine Depots

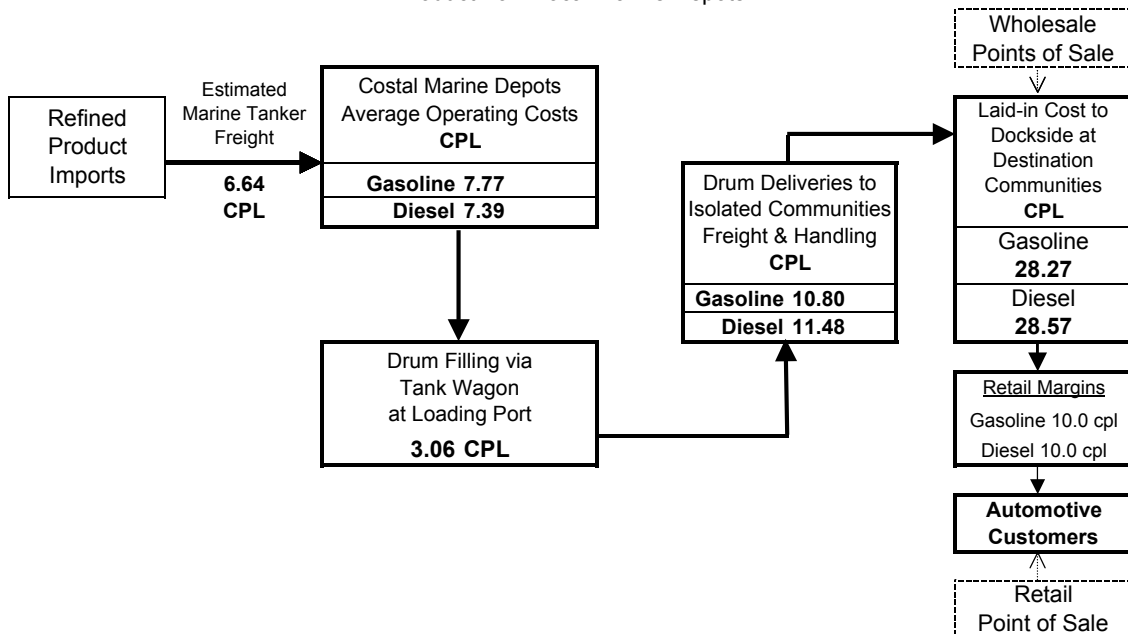

# APPENDIX F

## FIGURE 12

SUPPLY CHAIN COST DIAGRAM

### Retail Automotive Fuels Zone 12 - Central Labrador (Goose Bay and Area) Product from Goose Bay Terminals

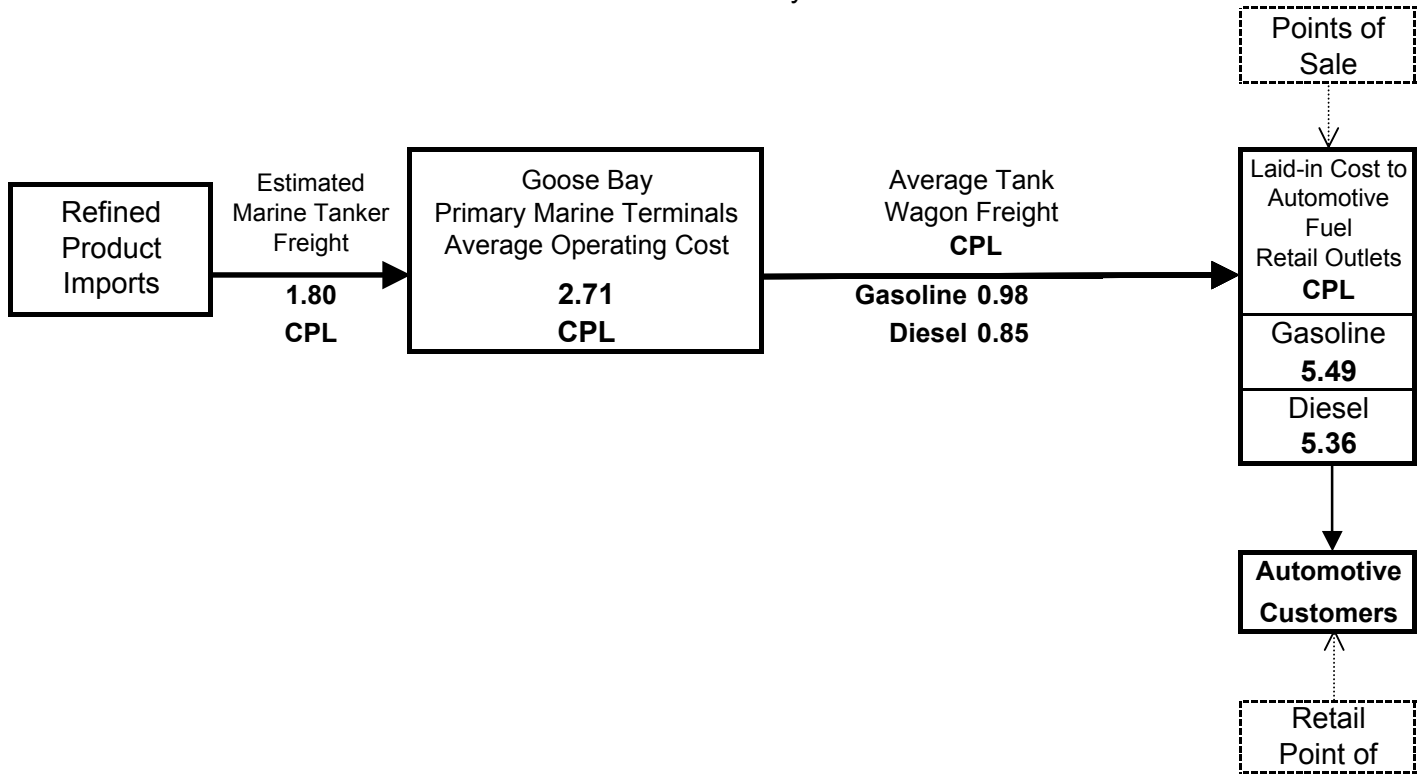

# APPENDIX F

## FIGURE 13

SUPPLY CHAIN COST DIAGRAM

### Retail Automotive Fuels Zone 13 - Western Labrador (Labrador City and Wabush) Product from Labrador City Rail Bulk Plant

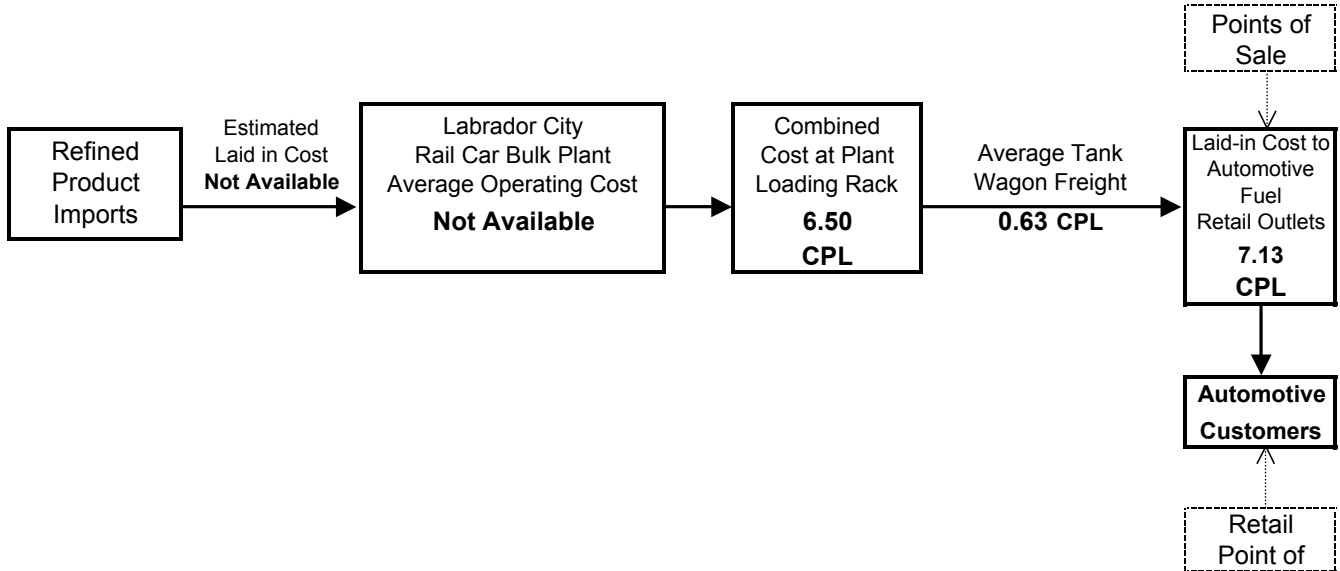

## FIGURE 13a

SUPPLY CHAIN COST DIAGRAM

### Retail Automotive Fuels Zone 13a - Churchill Falls - Western Labrador Product from Labrador City Rail Bulk Plant

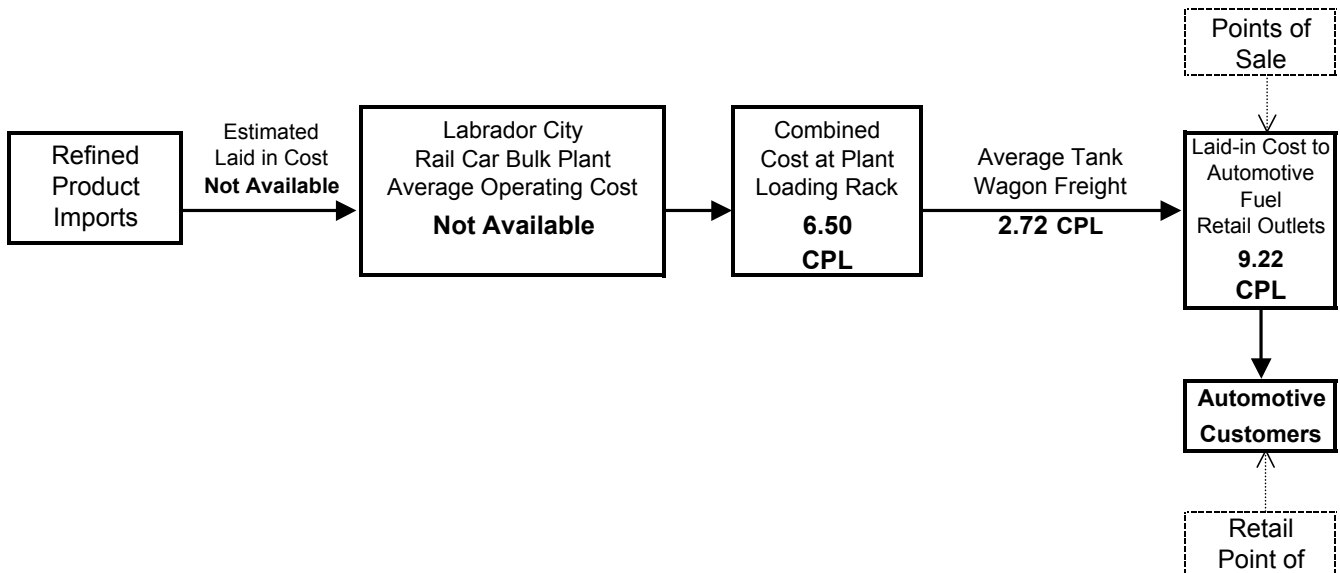

**APPENDIX F**

**FIGURE 13a**

**FIGURE 14**

**SUPPLY CHAIN COST DIAGRAM**

**Retail Automotive Fuels**  
**Zone 14 - Labrador Coast North - (Isolated Communities)**  
Product from Local Marine Depots

